

LOW PROFILE SEMI-AUTOMATIC STRETCH WRAPPER

SYNTHESI PALLET WRAPPER



SYNTHESI

Input: 110 Volt / 60 Hz
1 PHASE

CONTROL
PANEL



POWER ROLLER
STRETCH FILM
CARRIAGE

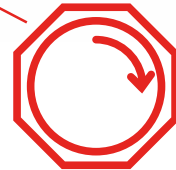

TURNTABLE

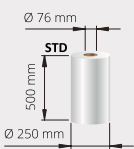

PALLET DIMENSIONS



Max: 2000 Kg STD
Max: 3000 Kg OPT

H mm
2450 STD

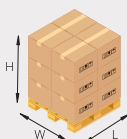

WxL mm
800x1200

MAX Ø mm
1500 STD

APPLICATIONS

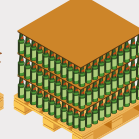

FEATURES



EASY TO
OPERATE



11" TOUCH
SCREEN



ADJUSTABLE
TENSION

OPTIONS

D184931 STRETCH WRAPPER ATLANTA SYNTHESI PRS (8'H - 59"D) 0005.00197

D184935 RAMP STANDARD ATLANTA SYNTHESI 0098.00011

D184936 RAMP EXTENDED REINFORCED SYNTHESI (For electric Pallet truck)

D184937 PHOTOCCELL BLACK PRODUCT SYNTHESI 0098.50020

D184938 PHOTOCCELL LASER TRANSPARENT PRODUCTS SYNTHESI 0098.50360

D184939 AUTOMATIC FILM CUTTING (CYCLEEND) 0098.00878

SPECIFICATIONS

Production capacity:	20 Loads/Hour **
Maximum load weight:	4410 lbs
Frame type:	Low profile
Standard wrapping height:	2450 mm
Turntable diameter:	1500 mm
Adjustable turntable rotation speed facilitated by frequency inverter:	From 5 to 12 rpm*
Standard voltage:	110 V - 60 Hz – 1 Ph

* Depending on configuration

** Depending on film quality and working environment:

Wrapping conditions and pallet dimensions have an influence on the Max output capacity

MACHINE DIMENSIONS SYNTHESI

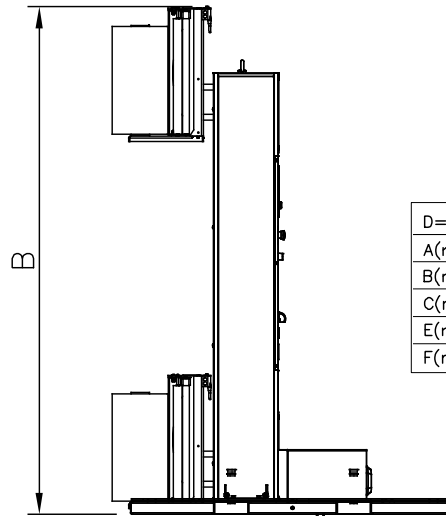
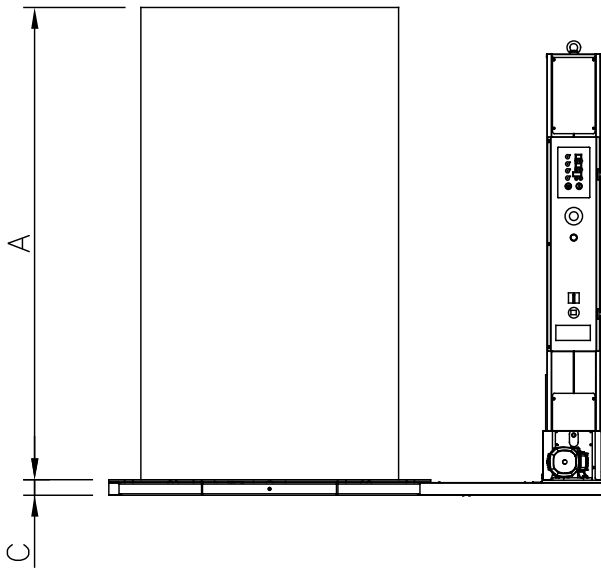

D=1500(mm)	
A(mm)	2500
B(mm)	2665
C(mm)	73
E(mm)	2300
F(mm)	1510

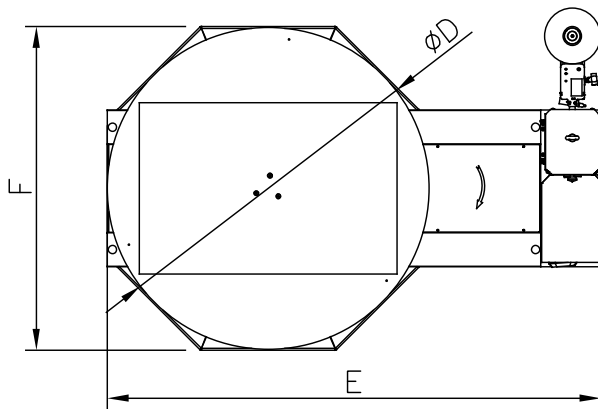

WHY THE SYNTHESI STRETCH WRAPPER?

BEST VALUE FOR MONEY

SYNTHESI is an economical and easy to operate stretch wrapping machine, which is equipped with a film carriage FM / FE and OPRS. Enables you to own a POWER PRE-STRETCH machine for an affordable price. This model has a high demand by those users

wrapping limited pallets per day, and still interested in achieving low cost of ownership. SYNTHESI answers those needs. Already supplied as a fully equipped machine, many options are available for installation, in order to make this machine become your best partner in logistics.

DOVERCO
Strategic. Packaging.

www.doverco.ca | sales@doverco.ca | 1.800.363.0697