

Robot Stretch Wrap Machine

NEOS

SEMI AUTOMATIC
PALLET WRAPPER



www.doverco.ca | sales@doverco.ca

2111 32nd Avenue, Montreal, Quebec, H8T 3J1 | 250 Trowers Road, Unit 7, Vaughan, ON L4L 5Z6

1.800.363.0697

NEOS
 Input: 120 Volt
 1 PHASE

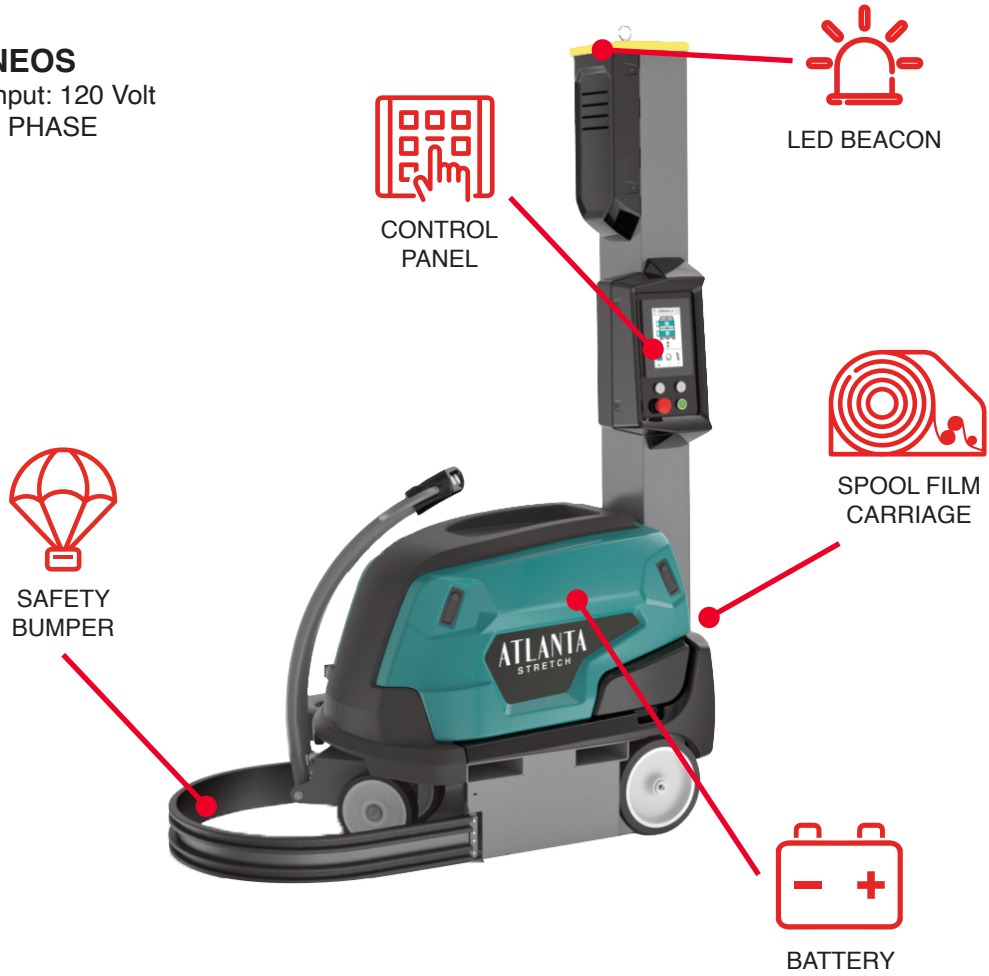

OPTIONAL



Film Cutter



Arya System

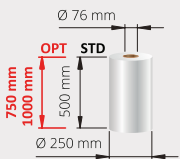

PALLET DIMENSIONS



H mm Mast
2200 STD
2450 OPT
2700 OPT
3200 OPT
3500 OPT
3900 OPT

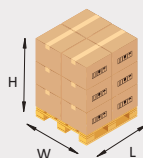

Neos
 L min = 650 x 400
 L Max = ∞

APPLICATIONS

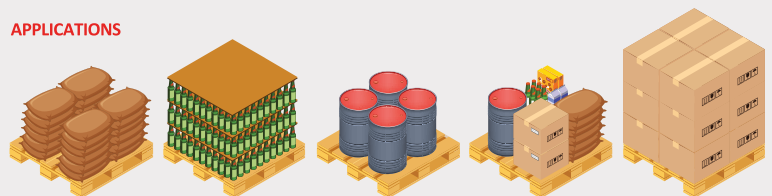

FEATURES



7" TOUCH
SCREEN



150-180 WRAPS
PER CHARGE



EASY
TO MOVE

SPECIFICATIONS	NEOS
Wrapping programs model NEOS:	Operating display 7" TOUCH with 99 Programs
Minimum pallet dimensions:	650 x 400 mm
Maximum pallet dimensions:	Pallet size can be programmed on the operating panel
Adjustable speed facilitated by frequency changer:	Max 65 m/min
Carriage braking system:	PS (ELECTRONIC PRE-STRETCH)
Standard wrapping height:	2200 mm
Optional wrapping height:	2400 / 2700 / 3000 / 3500 mm
Photocell detection of load height:	STANDARD SUPPLY
Adjustable Spool carriage speed facilitated by inverter:	From 1,3 up to 5,4 m/min
Upwards Spool carriage speed:	Independently settable
Downwards Spool carriage speed:	Independently settable
Lifting with fork lift truck:	STANDARD SUPPLY
Total installed power:	0.55 Kw
High frequency built-in battery charger:	120V 1PH 50/60 HZ
Standard charging voltage:	120V 1PH 50/60 HZ
Operating voltage:	24 V
Electrical and motor protection system:	IP 20
Output capacity:	35 Pallets per Hour *

*Wrapping conditions and pallet dimensions have an influence on the maximum output capacity

**Electronic adjustment from 120 to 350%

MACHINE DIMENSIONS NEOS

MACHINE DIMENSIONS IN MILLIMETERS

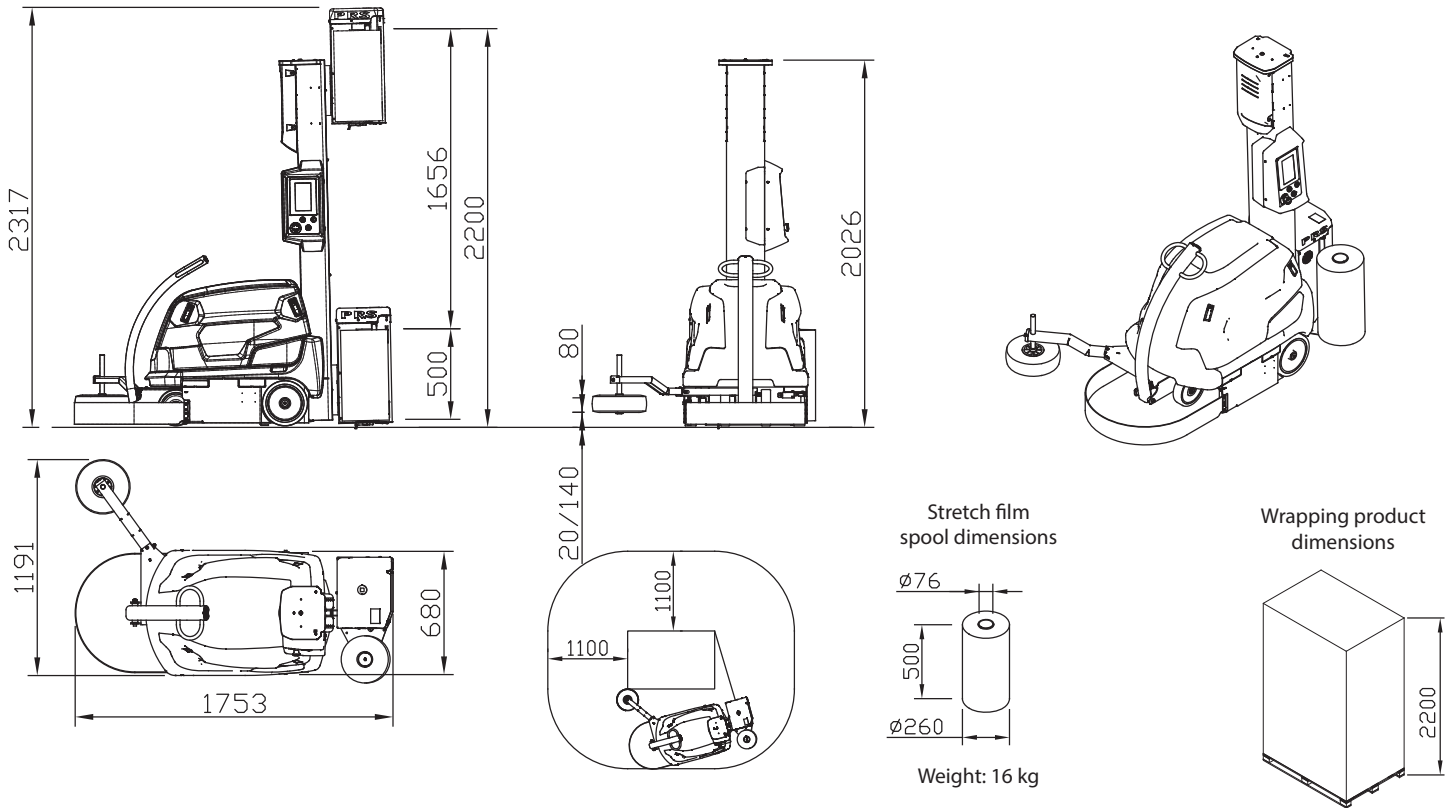

WHY THE NEOS STRETCH WRAPPER?

Wrap palletized loads in less than a minute...any size, shape or weight

- Compact size: easy to move and store
- Maintenance free
- Wrap up to 35 pallets/hour
- Adjustable pre-stretch with powered rollers...save 40–50% over hand wrapping

DOVERCO
Strategic. Packaging.

www.doverco.ca | sales@doverco.ca | 1.800.363.0697